

Model G8-80 Rotary Gear Pump

Surex rotary gear pumps designed for foam extinguishing system. They are Self-Priming and can pump Multiple Viscosities of Foam or Water. This versatile design is suitable for Electric, PTO, Diesel/Gasoline Engine, Water Driven or Hydraulic drive motors.

Design Features:

- Timing Gears Synchronize the Two Pumping Rotors.
- Timing Gears Allow for DRY Running Without Damage.
- No Rotor Contact Allows for Pumping Foam or Water.
- Water Can Be Used for: Calibration, Testing and Training.

Technical Data:

Max Pressure: 2.0MPa | 20bar
 Max Speed: 1800RPM
 Viscosity : 9500cp max.[1]
 Connection Diameter: DN65(73.0 O.D.)、2½"
 Connection Type: Groove、Thread、Flange
 Approvals: FM
 [1]Brookfield viscometer, spindle #4, speed 30rpm.

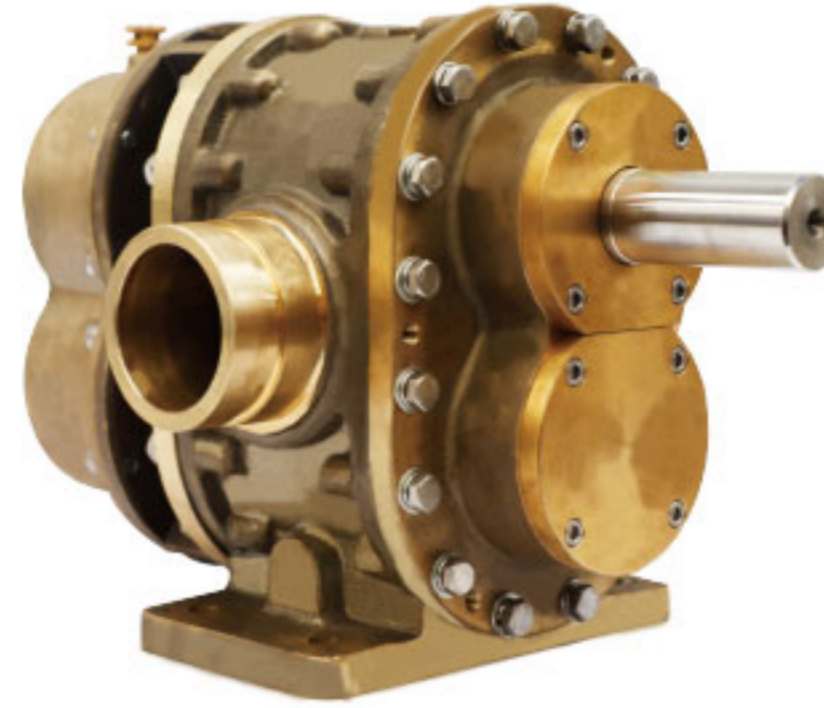

Materials :

Pump body: Red Brass, ASTM B584 C83600
 Rotor: Stainless Steel 17-4PH
 Red Brass, ASTM B584 C83600
 Liners: Red Brass, ASTM B584 C83600
 Front Cover: Red Brass, ASTM B584 C83600
 Back Cover: Red Brass ASTM B584 C83600
 Timing Gear: Alloy Steel 20CrMnTi (ASTM A29M)
 Lip Seal : FPM

Performance -Water

Foam Pump	1000rpm			1200rpm			1500rpm			1800rpm			
	Pressure PSI	Flow GPM	Power HP	Torque LB-FT	Flow GPM	Power HP	Torque LB-FT	Flow GPM	Power HP	Torque LB-FT	Flow GPM	Power HP	Torque LB-FT
	72.5	64	5	25	82	6	27	110	8	30	137	10	30
	100	60	6	33	78	8	35	106	11	38	133	13	39
	150	54	9	47	71	11	48	99	15	51	127	19	55
	200	48	11	61	66	14	61	94	19	65	121	24	70
	250	45	14	74	62	17	75	90	23	79	117	29	84
	290	43	16	85	60	19	86	87	26	91	114	32	94

Dimensions

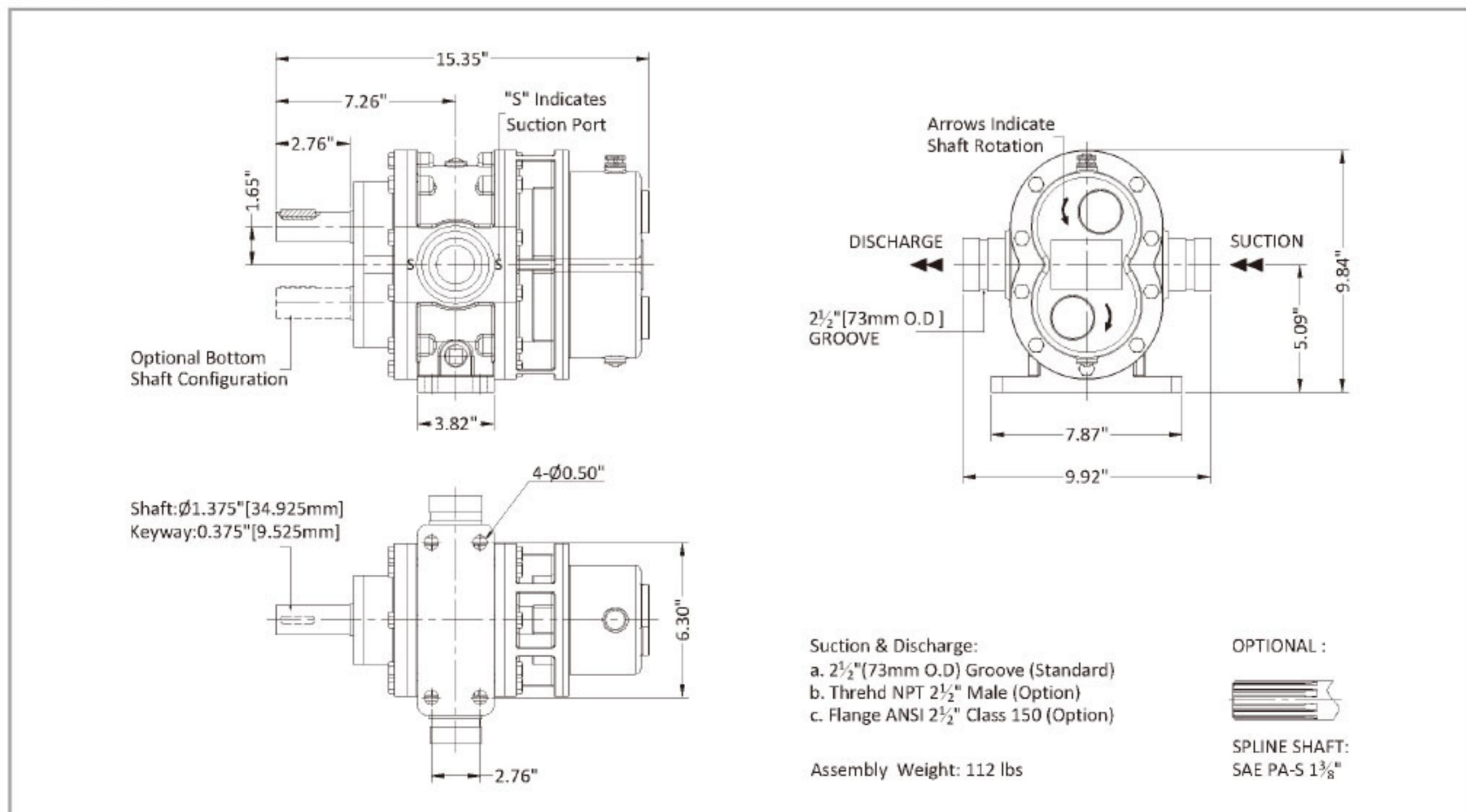

Model G8-80 Rotary Gear Pump

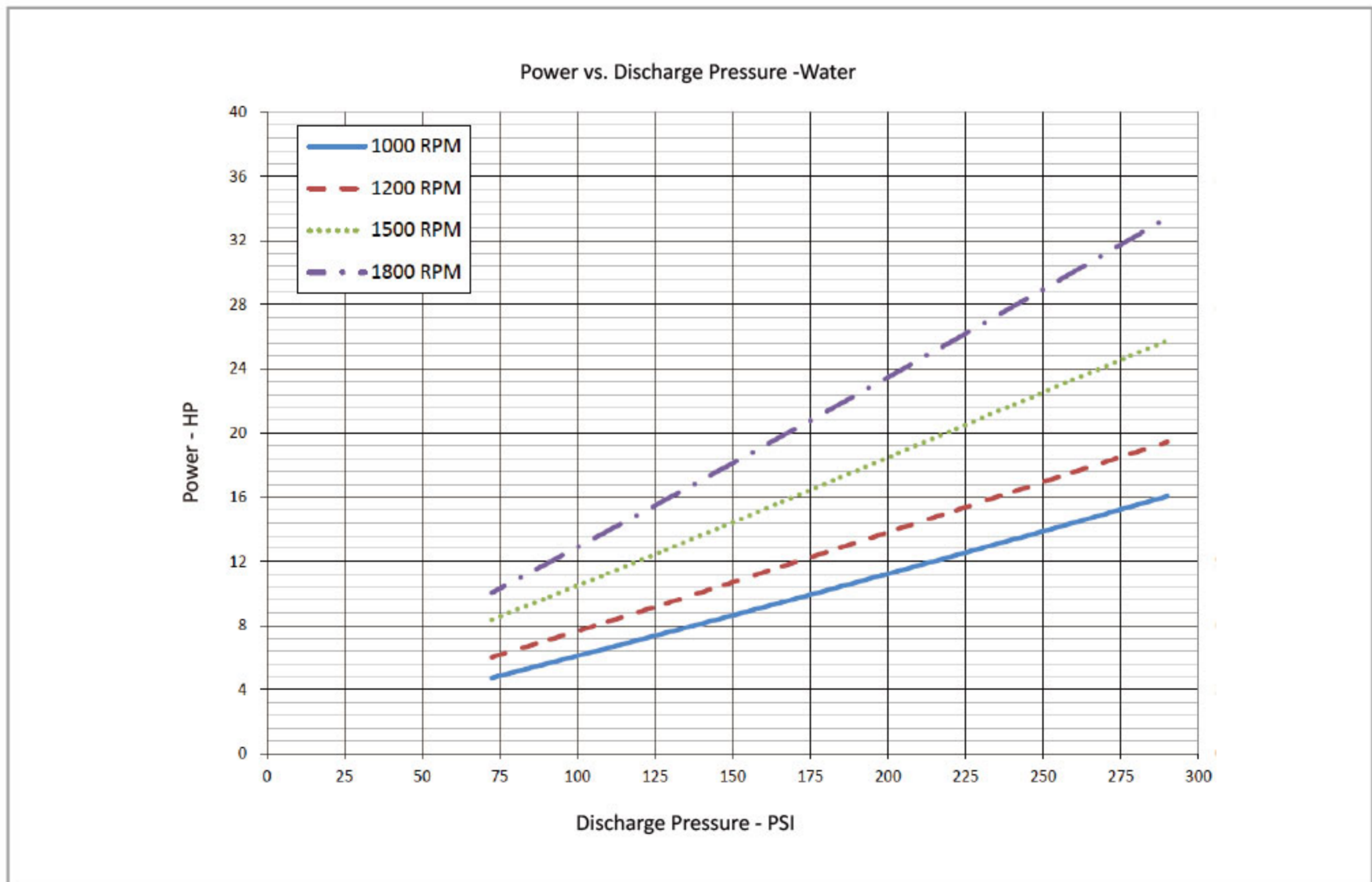
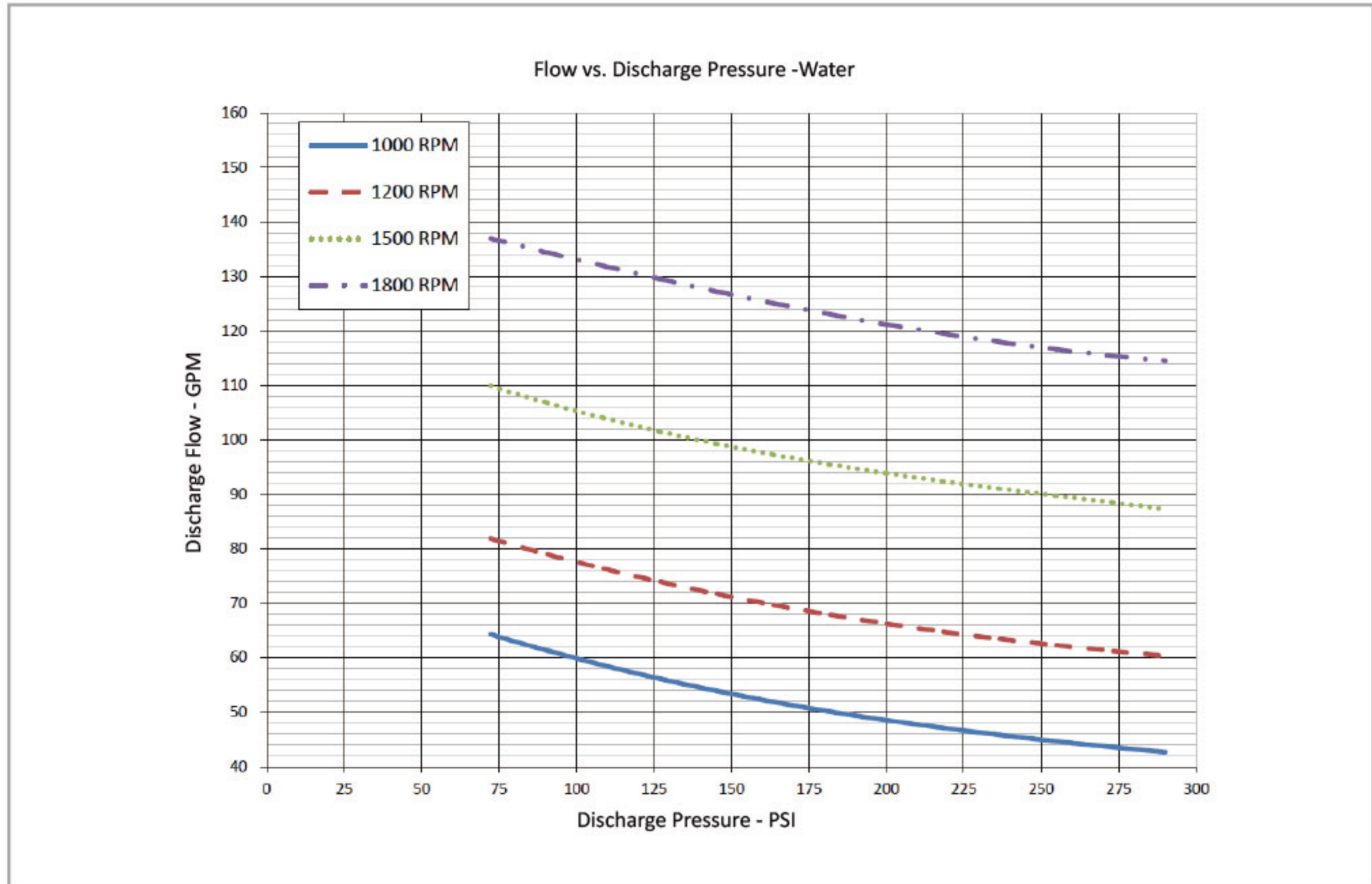

• The pump performance for foam concentrate, please contact Surex, or down load from www.surexfoam.com.