

Model G8T-132 Rotary Gear Pump

Surex rotary gear pumps designed for foam extinguishing system. They are Self-Priming and can pump Multiple Viscosities of Foam or Water. This versatile design is suitable for Electric, PTO, Diesel/Gasoline Engine, Water Driven or Hydraulic drive motors.

Design Features:

- Timing Gears Synchronize the Two Pumping Rotors.
- Timing Gears Allow for DRY Running Without Damage.
- No Rotor Contact Allows for Pumping Foam or Water.
- Water Can Be Used for: Calibration, Testing and Training.

Technical Data:

Max Pressure: 2.0MPa | 20bar
Max Speed: 1800RPM
Viscosity : 9500cp max.[1]
Connection Diameter: DN100(114.3 O.D.)、4"
Connection Type: Groove、Thread、Flange
Approvals: FM
[1]Brookfield viscometer, spindle #4, speed 30rpm.

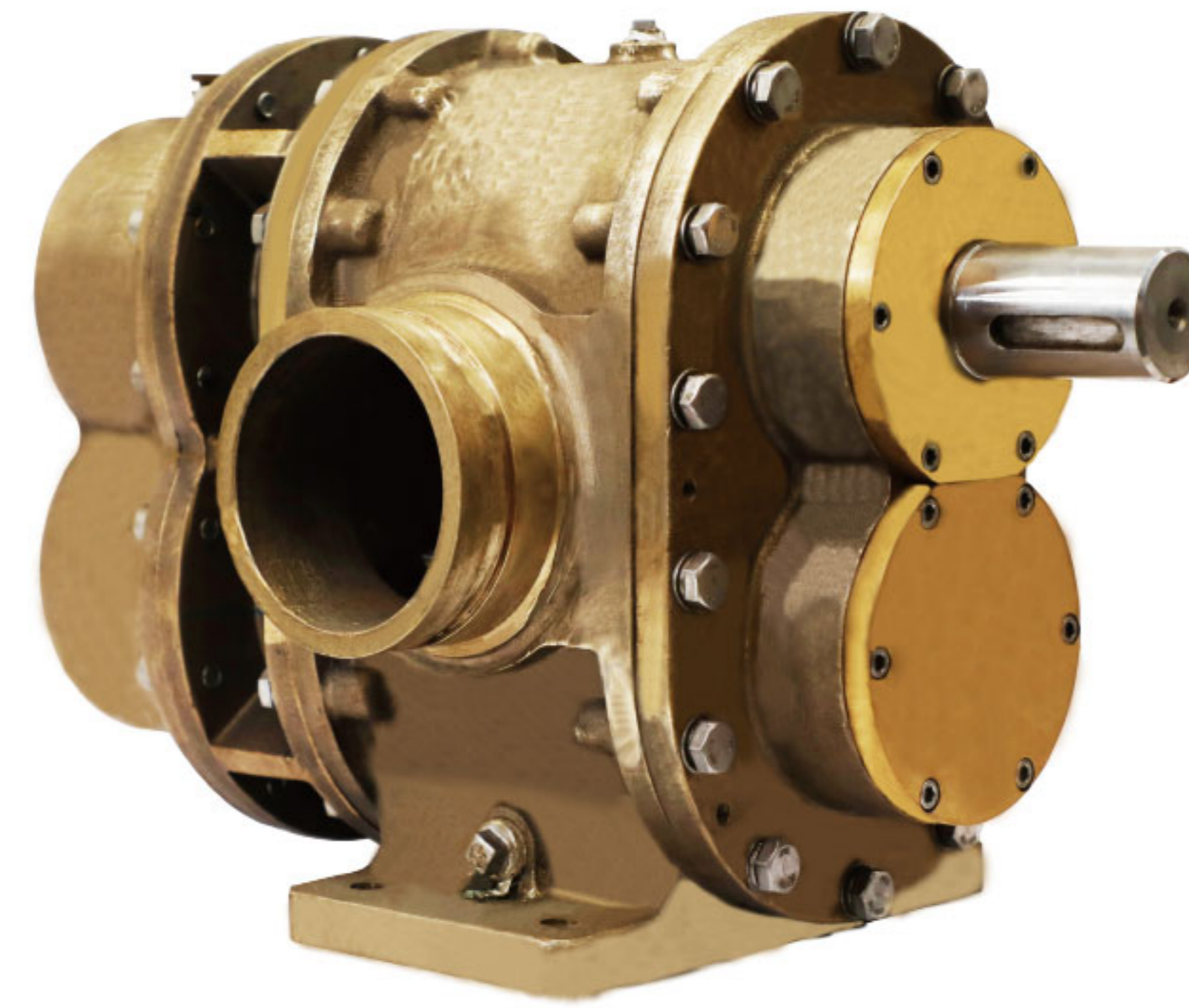

Materials :

Pump body: Red Brass, ASTM B584 C83600
Rotor: Stainless Steel 17-4PH
Red Brass, ASTM B584 C83600
Liners: Red Brass, ASTM B584 C83600
Front Cover: Red Brass, ASTM B584 C83600
Back Cover: Red Brass ASTM B584 C83600
Timing Gear: Alloy Steel 20CrMnTi (ASTM A29M)
Lip Seal : FPM

Performance -Water

Foam Pump	1000rpm			1200rpm			1500rpm			1800rpm			
	Pressure	Flow	Power	Torque	Flow	Power	Torque	Flow	Power	Torque	Flow	Power	Torque
	PSI	GPM	HP	LB-FT	GPM	HP	LB-FT	GPM	HP	LB-FT	GPM	HP	LB-FT
	72.5	166	12	63	200	16	69	263	23	80	317	32	67
	100	159	15	79	196	20	86	257	28	97	313	37	78
	150	150	21	109	189	27	117	249	36	127	307	47	99
	200	143	26	140	184	34	149	244	45	158	301	58	120
	250	139	32	171	180	41	180	241	54	190	296	68	141
	290	137	37	197	178	47	205	240	61	216	293	77	158

Dimensions

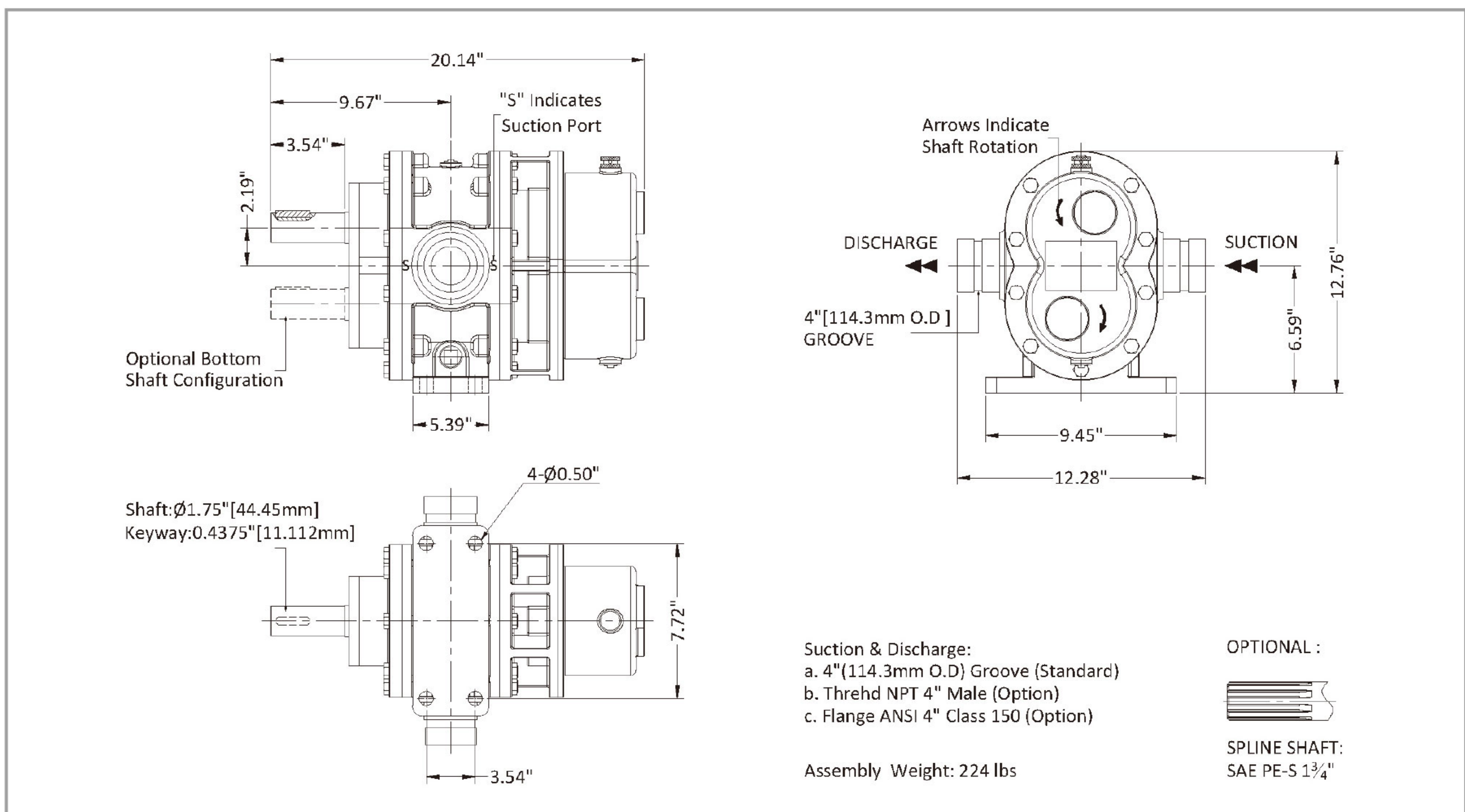

Model G8T-132 Rotary Gear Pump

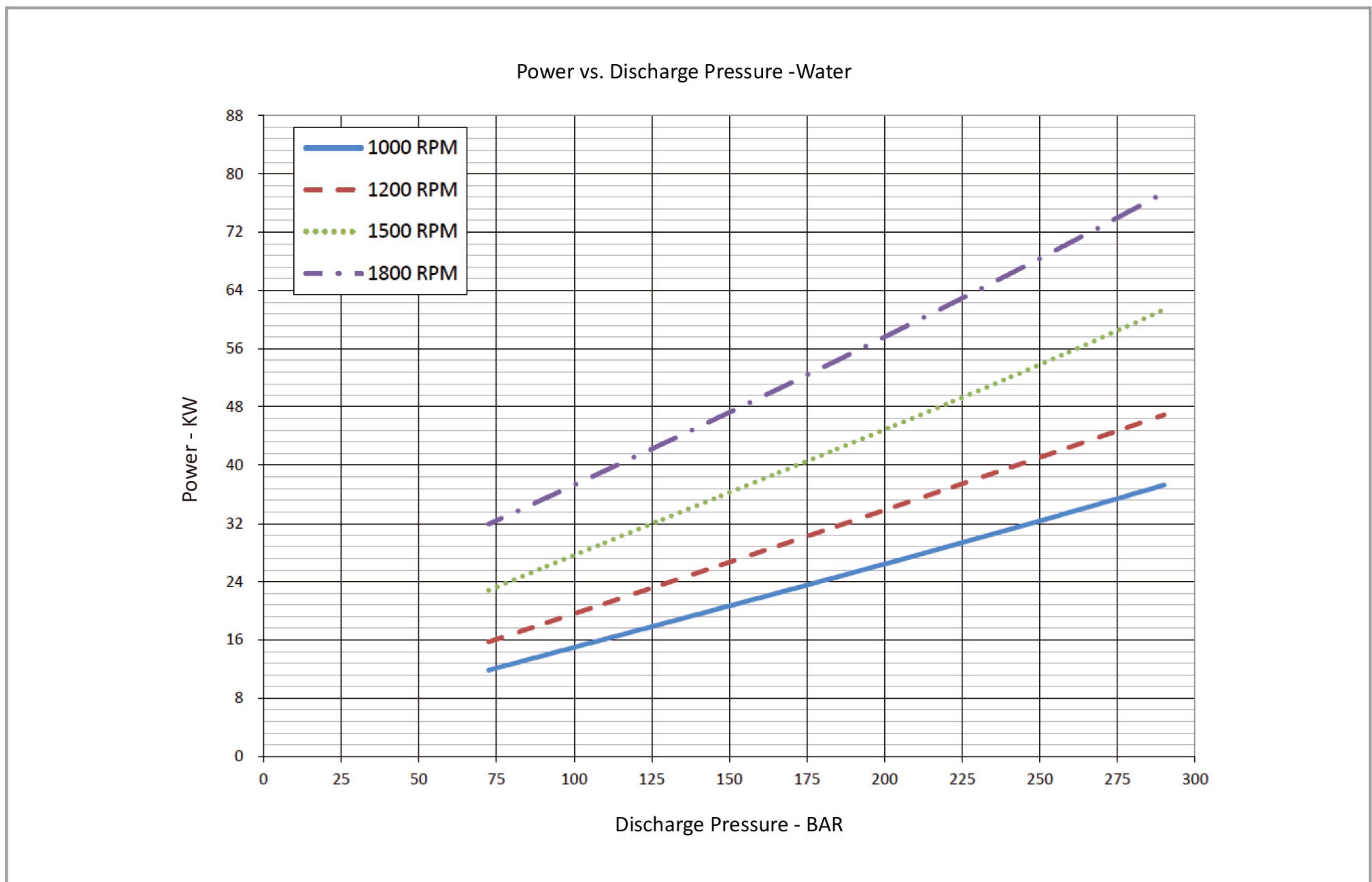
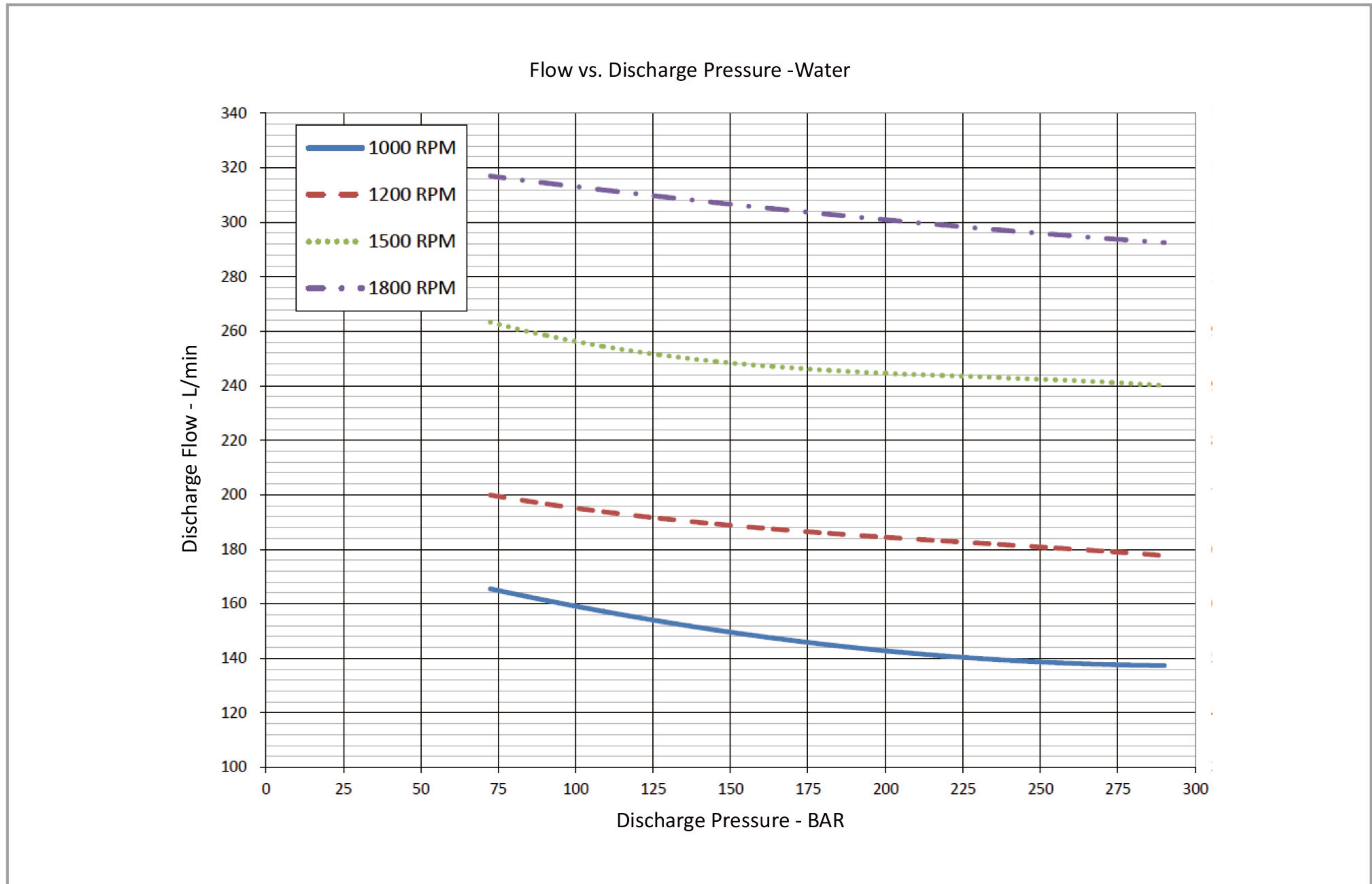

• The pump performance for foam concentrate, please contact Surex, or down load from www.surexfoam.com.