

Model G8T-120 Rotary Gear Pump

Surex rotary gear pumps designed for foam extinguishing system. They are Self-Priming and can pump Multiple Viscosities of Foam or Water. This versatile design is suitable for Electric, PTO, Diesel/Gasoline Engine, Water Driven or Hydraulic drive motors.

Design Features:

- Timing Gears Synchronize the Two Pumping Rotors.
- Timing Gears Allow for DRY Running Without Damage.
- No Rotor Contact Allows for Pumping Foam or Water.
- Water Can Be Used for: Calibration, Testing and Training.

Technical Data:

Max Pressure: 2.0MPa | 20bar
 Max Speed: 1800RPM
 Viscosity : 9500cp max.[1]
 Connection Diameter: DN100(114.3 O.D.)、4"
 Connection Type: Groove、Thread、Flange
 Approvals: FM
 [1]Brookfield viscometer, spindle #4, speed 30rpm.

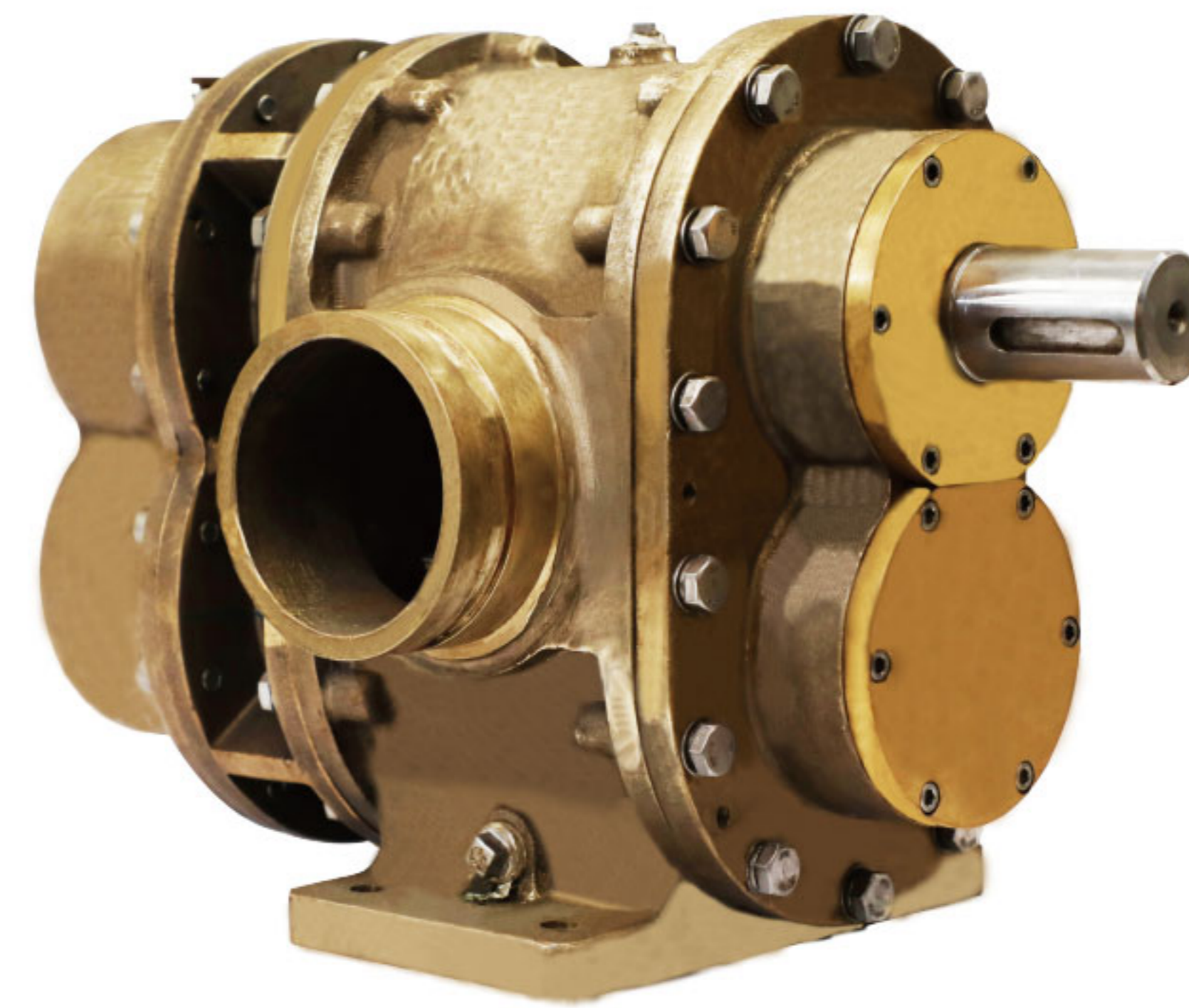

Materials :

Pump body: Red Brass, ASTM B584 C83600
 Rotor: Stainless Steel 17-4PH
 Red Brass, ASTM B584 C83600
 Liners: Red Brass, ASTM B584 C83600
 Front Cover: Red Brass, ASTM B584 C83600
 Back Cover: Red Brass ASTM B584 C83600
 Timing Gear: Alloy Steel 20CrMnTi (ASTM A29M)
 Lip Seal : FPM

Performance -Water

Foam Pump	1000rpm			1200rpm			1500rpm			1800rpm		
Pressure	Flow	Power	Torque	Flow	Power	Torque	Flow	Power	Torque	Flow	Power	Torque
PSI	GPM	HP	LB-FT	GPM	HP	LB-FT	GPM	HP	LB-FT	GPM	HP	LB-FT
72.5	151	11	61	187	15	68	241	21	75	287	29	86
100	146	15	77	181	19	83	236	26	91	282	34	101
150	137	20	106	173	25	110	228	34	120	275	44	128
200	131	25	133	167	31	137	223	42	149	269	53	156
250	126	31	161	163	38	166	218	51	178	265	63	185
290	124	35	183	161	43	190	216	57	202	263	71	209

Dimensions

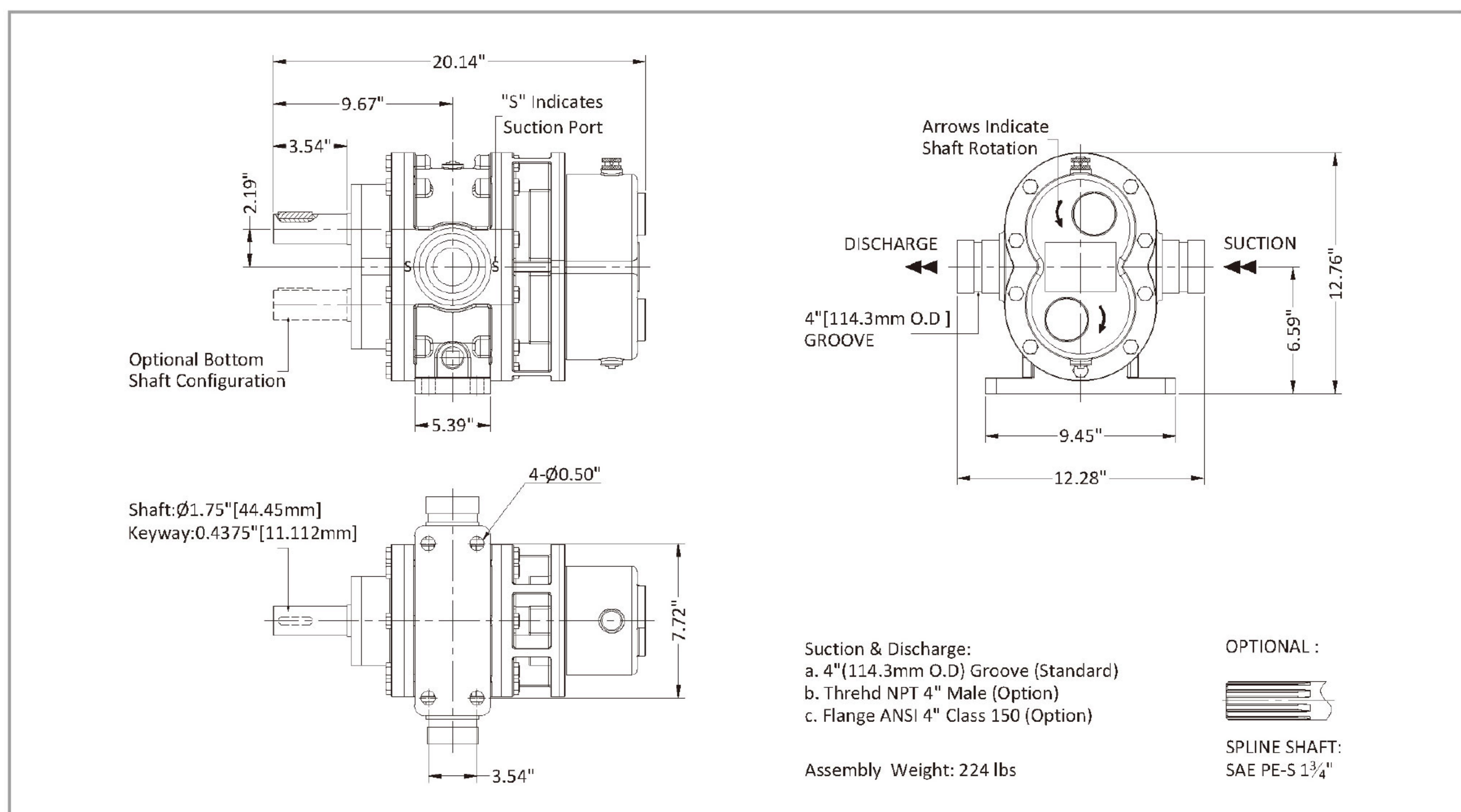

Model G8T-120 Rotary Gear Pump

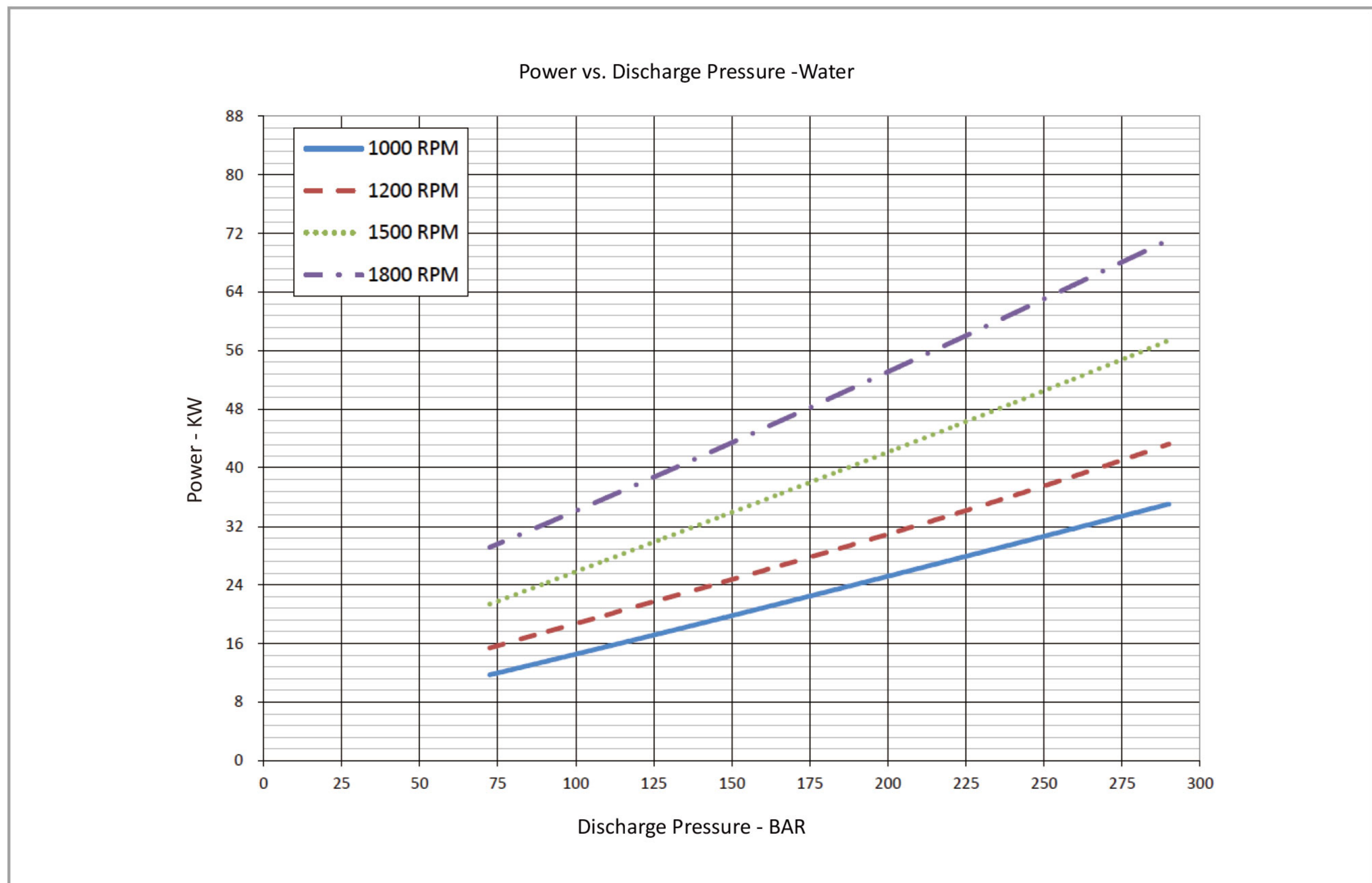
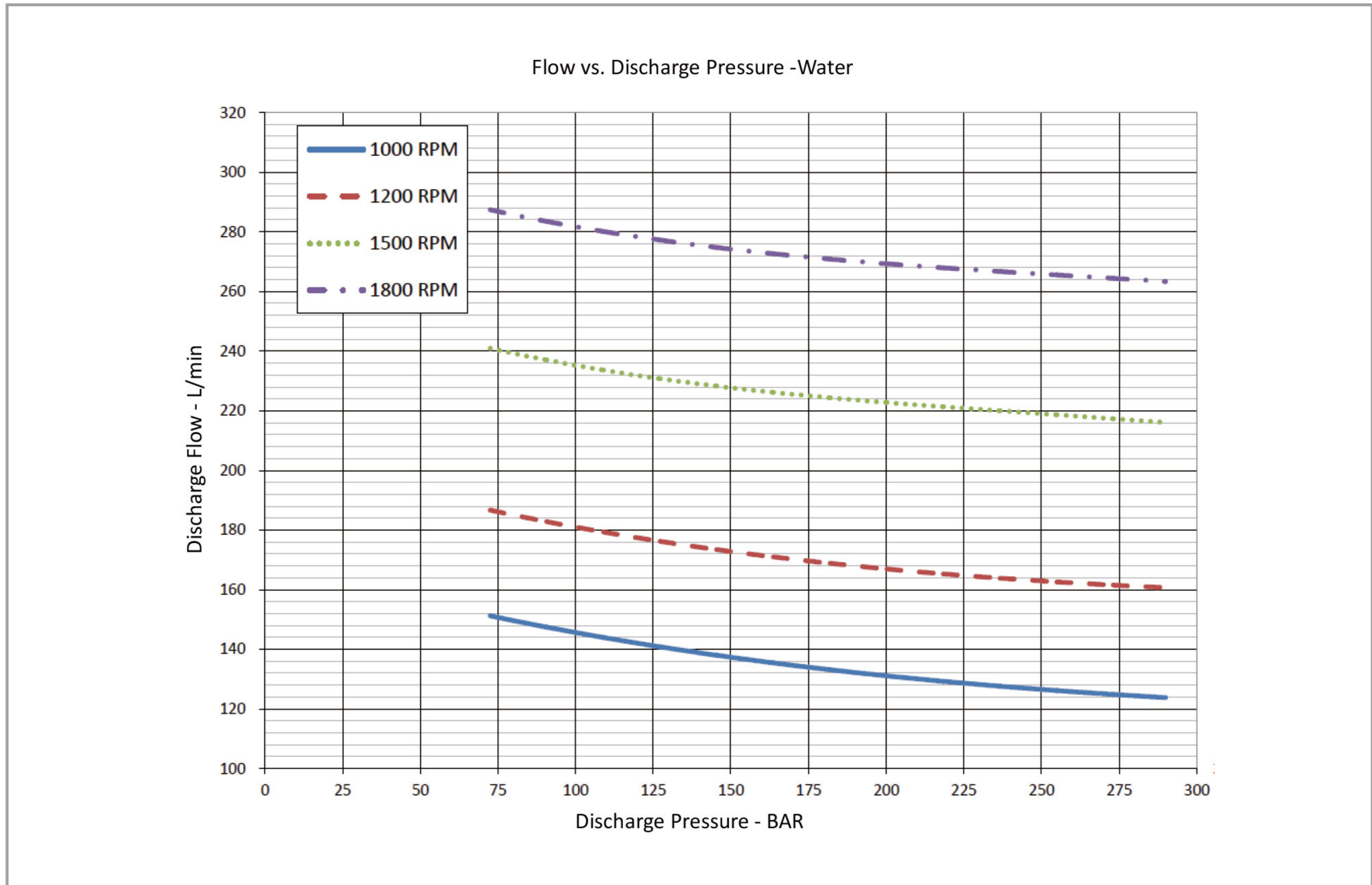

• The pump performance for foam concentrate, please contact Surex, or down load from www.surexfoam.com.