

Model G8-92 Rotary Gear Pump

Surex rotary gear pumps designed for foam extinguishing system. They are Self-Priming and can pump Multiple Viscosities of Foam or Water. This versatile design is suitable for Electric, PTO, Diesel/Gasoline Engine, Water Driven or Hydraulic drive motors.

Design Features:

- Timing Gears Synchronize the Two Pumping Rotors.
- Timing Gears Allow for DRY Running Without Damage.
- No Rotor Contact Allows for Pumping Foam or Water.
- Water Can Be Used for: Calibration, Testing and Training.

Technical Data:

Max Pressure: 2.0MPa | 20bar
 Max Speed: 1800RPM
 Viscosity : 9500cp max.[1]
 Connection Diameter: DN65(73.0 O.D.)、2½"
 Connection Type: Groove、Thread、Flange
 Approvals: FM
 [1]Brookfield viscometer, spindle #4, speed 30rpm.

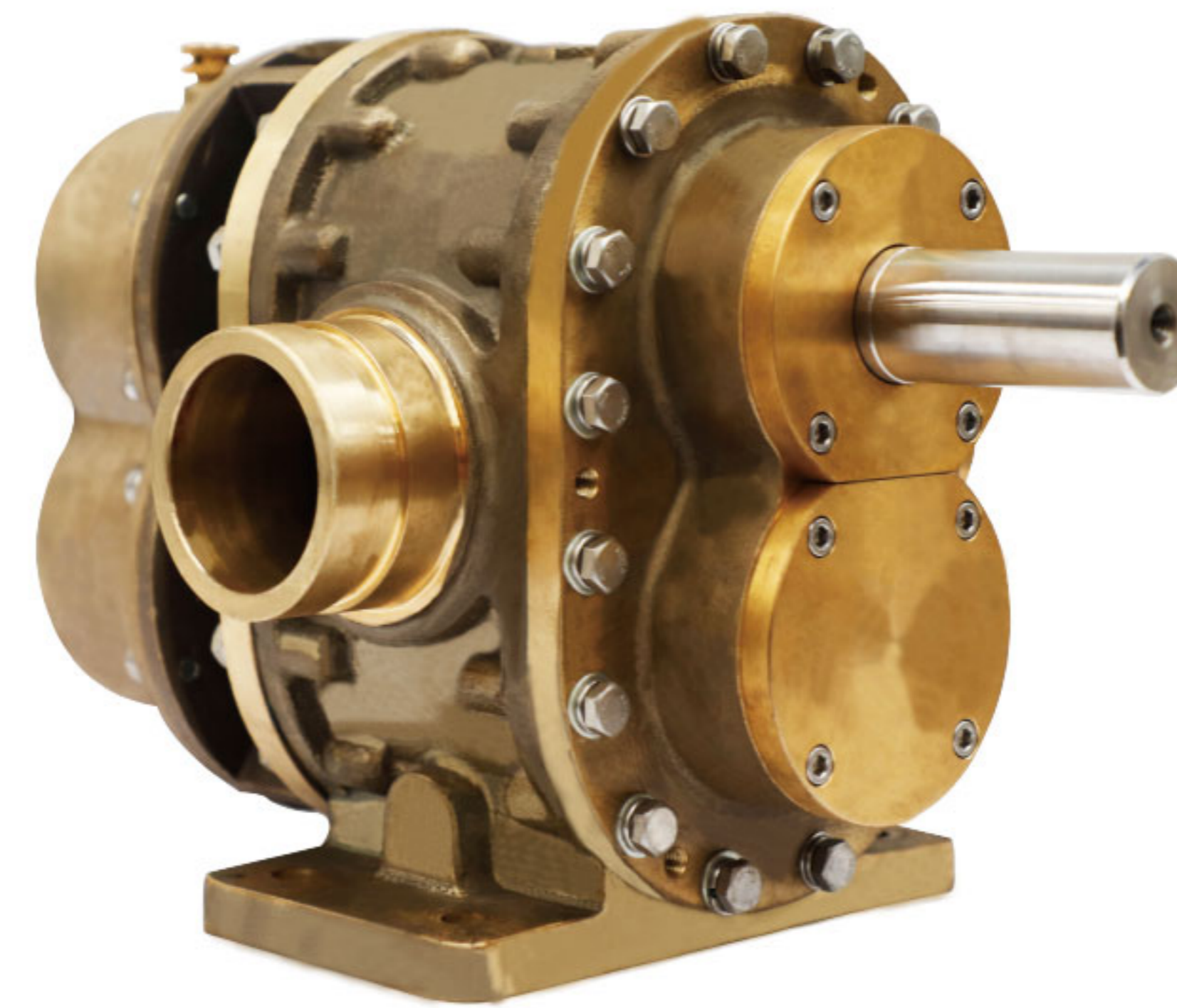

Materials :

Pump body: Red Brass, ASTM B584 C83600
 Rotor: Stainless Steel 17-4PH
 Red Brass, ASTM B584 C83600
 Liners: Red Brass, ASTM B584 C83600
 Front Cover: Red Brass, ASTM B584 C83600
 Back Cover: Red Brass ASTM B584 C83600
 Timing Gear: Alloy Steel 20CrMnTi (ASTM A29M)
 Lip Seal : FPM

Performance -Water

Foam Pump	1000rpm			1200rpm			1500rpm			1800rpm			
	Pressure PSI	Flow GPM	Power HP	Torque LB-FT	Flow GPM	Power HP	Torque LB-FT	Flow GPM	Power HP	Torque LB-FT	Flow GPM	Power HP	Torque LB-FT
	72.5	68	6	30	89	7	30	120	9	33	152	12	36
	100	63	7	39	83	9	39	115	12	42	147	15	44
	150	55	10	55	75	13	56	107	16	58	139	21	60
	200	50	13	70	70	16	72	102	21	73	133	26	77
	250	47	16	85	67	20	88	98	25	89	129	32	95
	290	46	18	97	66	23	100	97	29	102	128	37	109

Dimensions

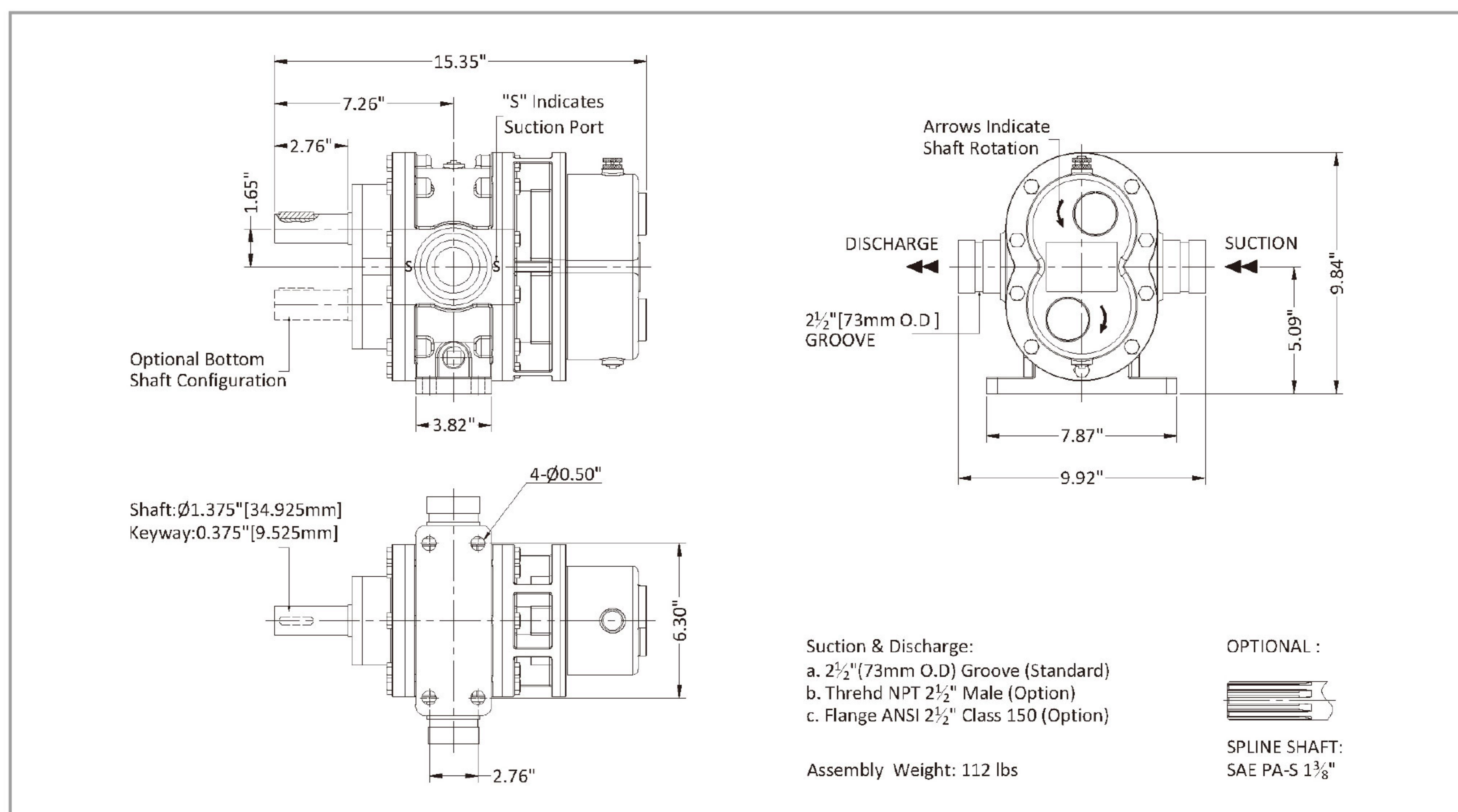

Model G8-92 Rotary Gear Pump

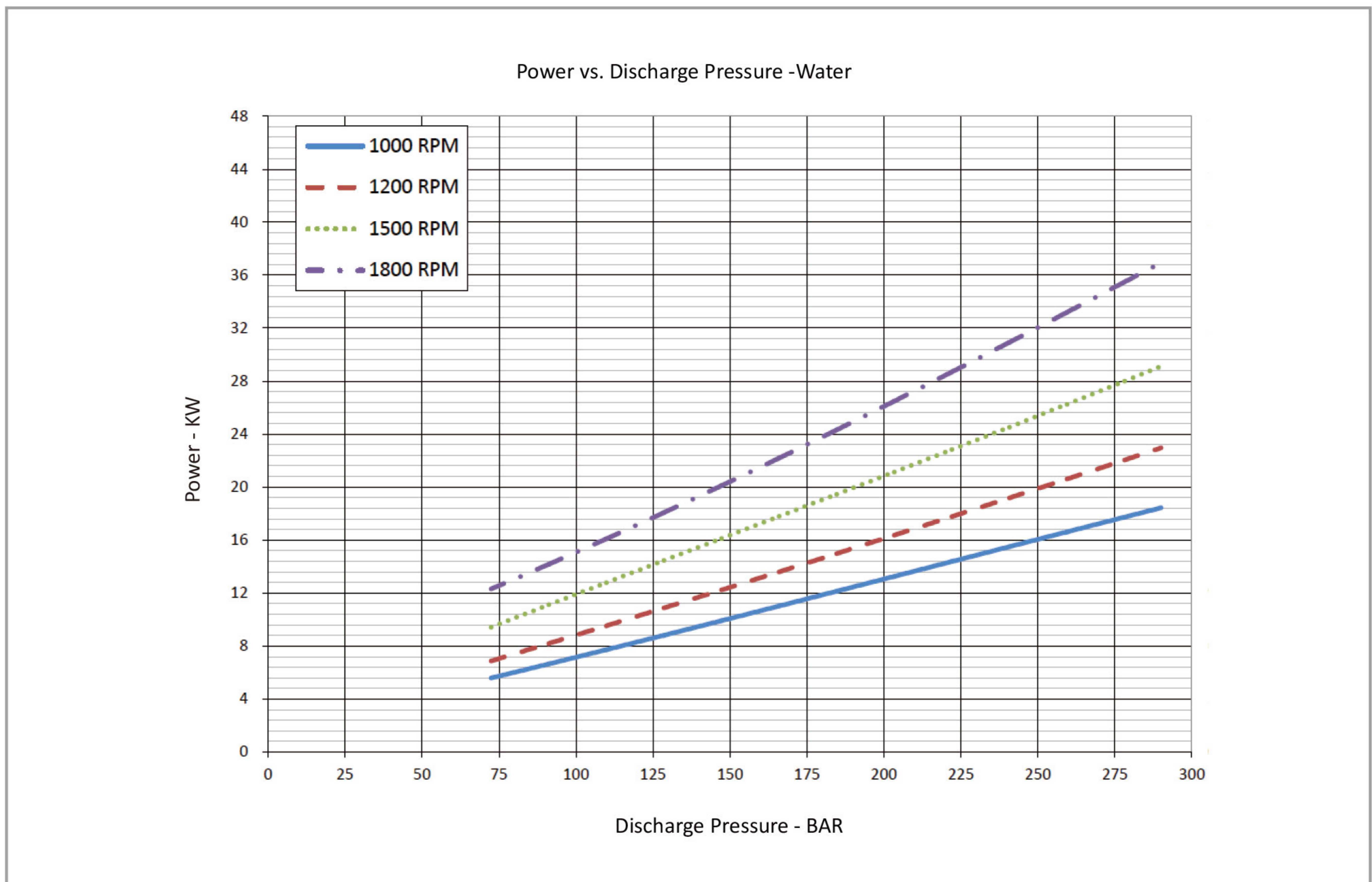
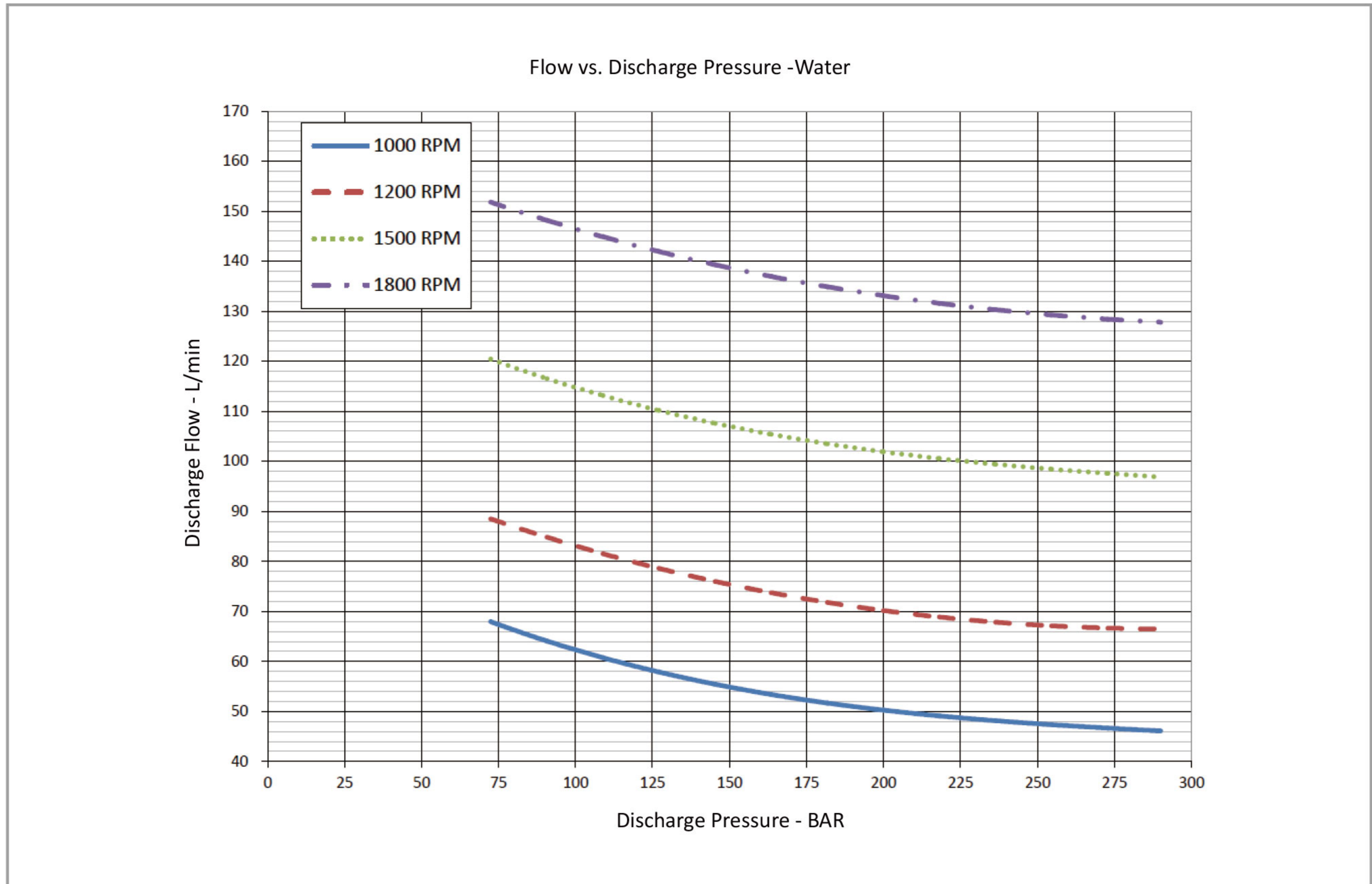

- The pump performance for foam concentrate, please contact Surex, or down load from www.surexfoam.com.