

Model G8-92 Rotary Gear Pump

Surex rotary gear pumps designed for foam extinguishing system. They are Self-Priming and can pump Multiple Viscosities of Foam or Water. This versatile design is suitable for Electric, PTO, Diesel/Gasoline Engine, Water Driven or Hydraulic drive motors.

Design Features:

- Timing Gears Synchronize the Two Pumping Rotors.
- Timing Gears Allow for DRY Running Without Damage.
- No Rotor Contact Allows for Pumping Foam or Water.
- Water Can Be Used for: Calibration, Testing and Training.

Technical Data:

Max Pressure: 2.0MPa | 20bar
Max Speed: 1800RPM
Viscosity : 9500cp max.[1]
Connection Diameter: DN65(76.1 O.D.)、2½"
Connection Type: Groove、Thread、Flange
Approvals: FM
[1]Brookfield viscometer, spindle #4, speed 30rpm.

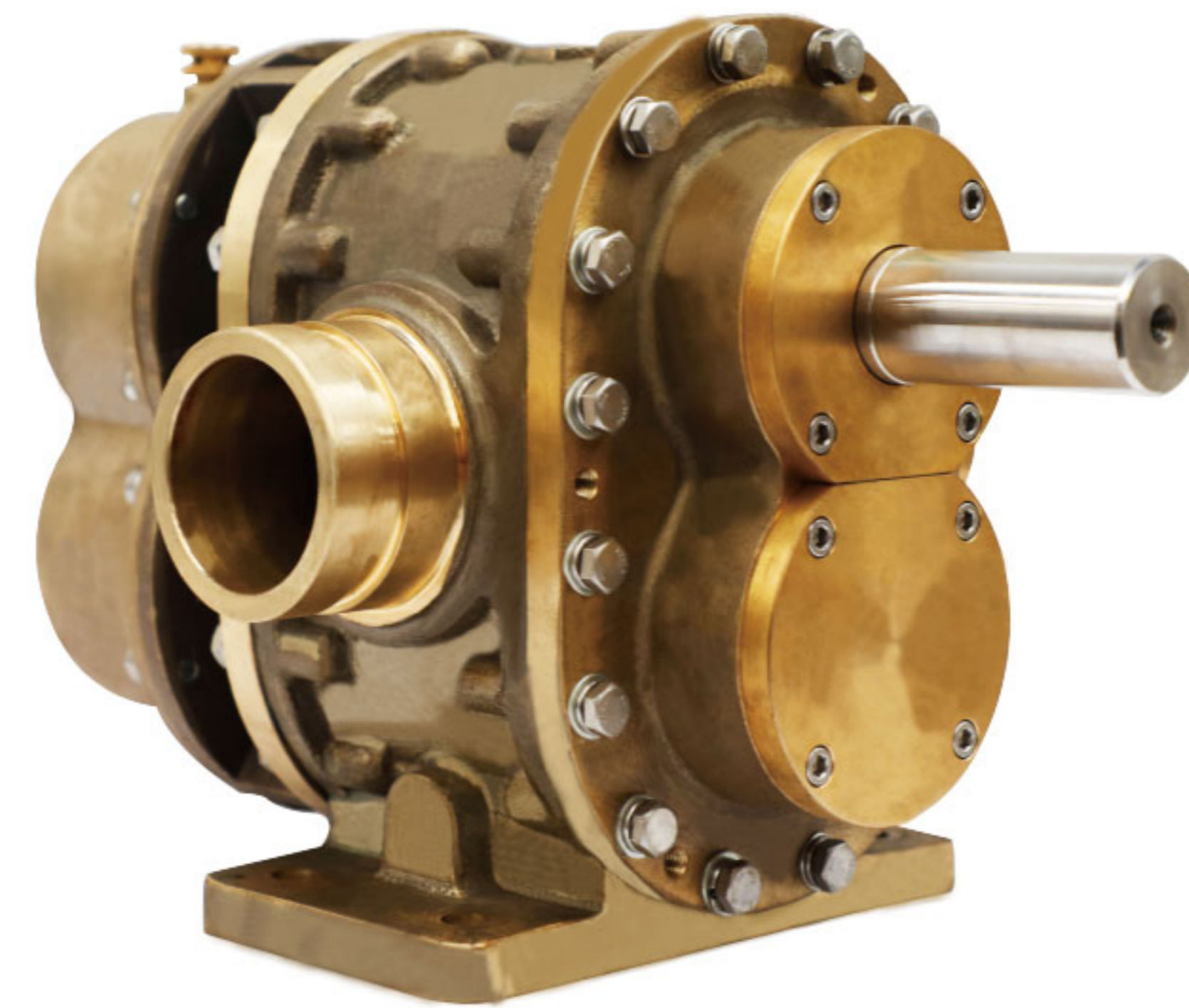

Materials :

Pump body: Red Brass, ASTM B584 C83600
Rotor: Stainless Steel 17-4PH
Red Brass, ASTM B584 C83600
Liners: Red Brass, ASTM B584 C83600
Front Cover: Red Brass, ASTM B584 C83600
Back Cover: Red Brass ASTM B584 C83600
Timing Gear: Alloy Steel 20CrMnTi (ASTM A29M)
Lip Seal : FPM

Performance -Water

Foam Pump	1000rpm			1200rpm			1500rpm			1800rpm			
	Pressure	Flow	Power	Torque	Flow	Power	Torque	Flow	Power	Torque	Flow	Power	Torque
	bar	L/min	kw	N.m	L/min	kw	N.m	L/min	kw	N.m	L/min	kw	N.m
	5.0	257	4	40	335	5	41	456	7	45	575	9	49
	6.9	237	5	53	315	7	53	435	9	57	555	11	60
	10.3	209	8	74	286	9	76	406	12	78	525	16	82
	13.8	190	10	95	266	12	98	385	16	99	504	20	105
	17.2	178	12	116	254	15	119	372	19	121	490	24	129
	20.0	175	14	132	252	17	135	367	22	138	484	28	147

Dimensions

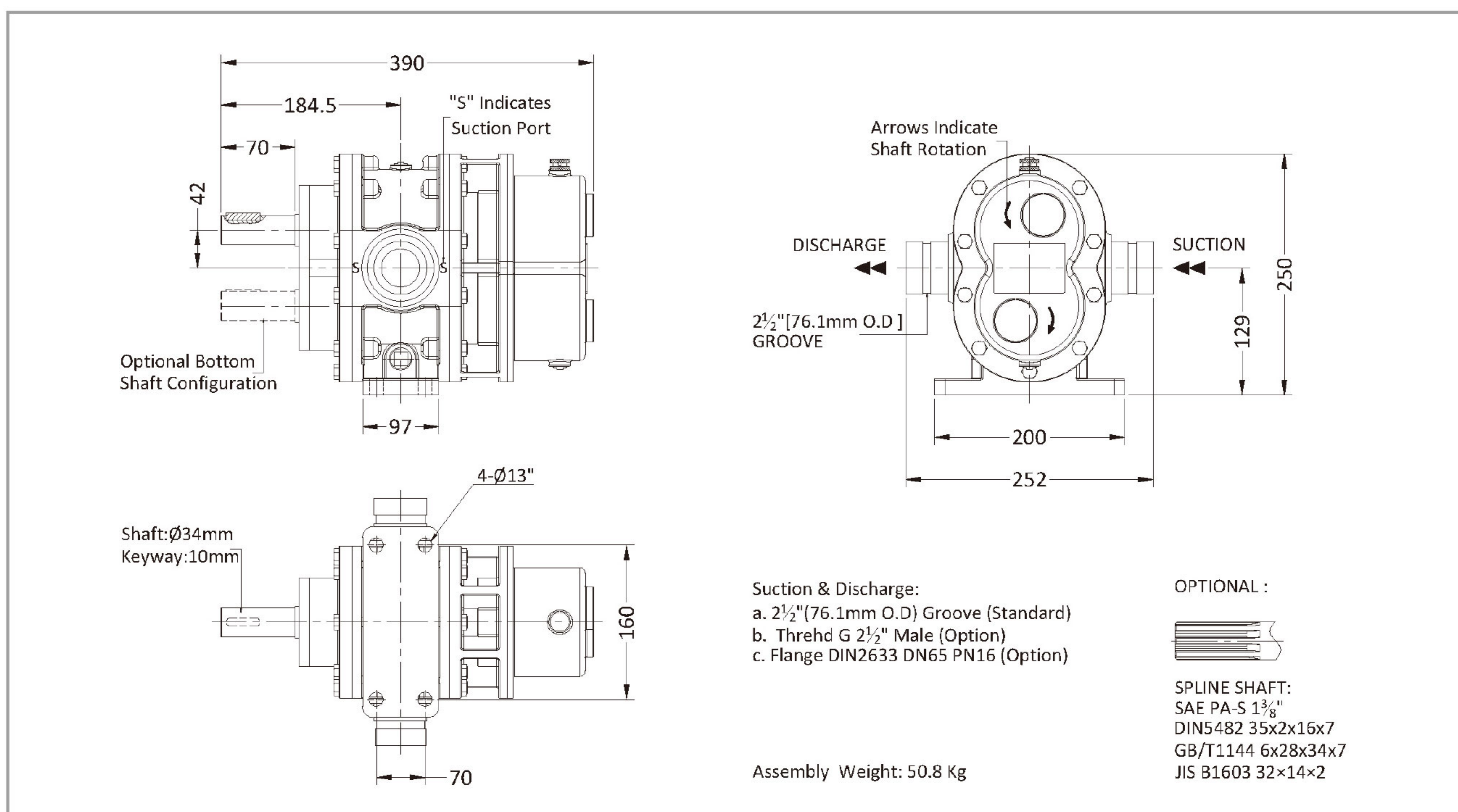

Model G8-92 Rotary Gear Pump

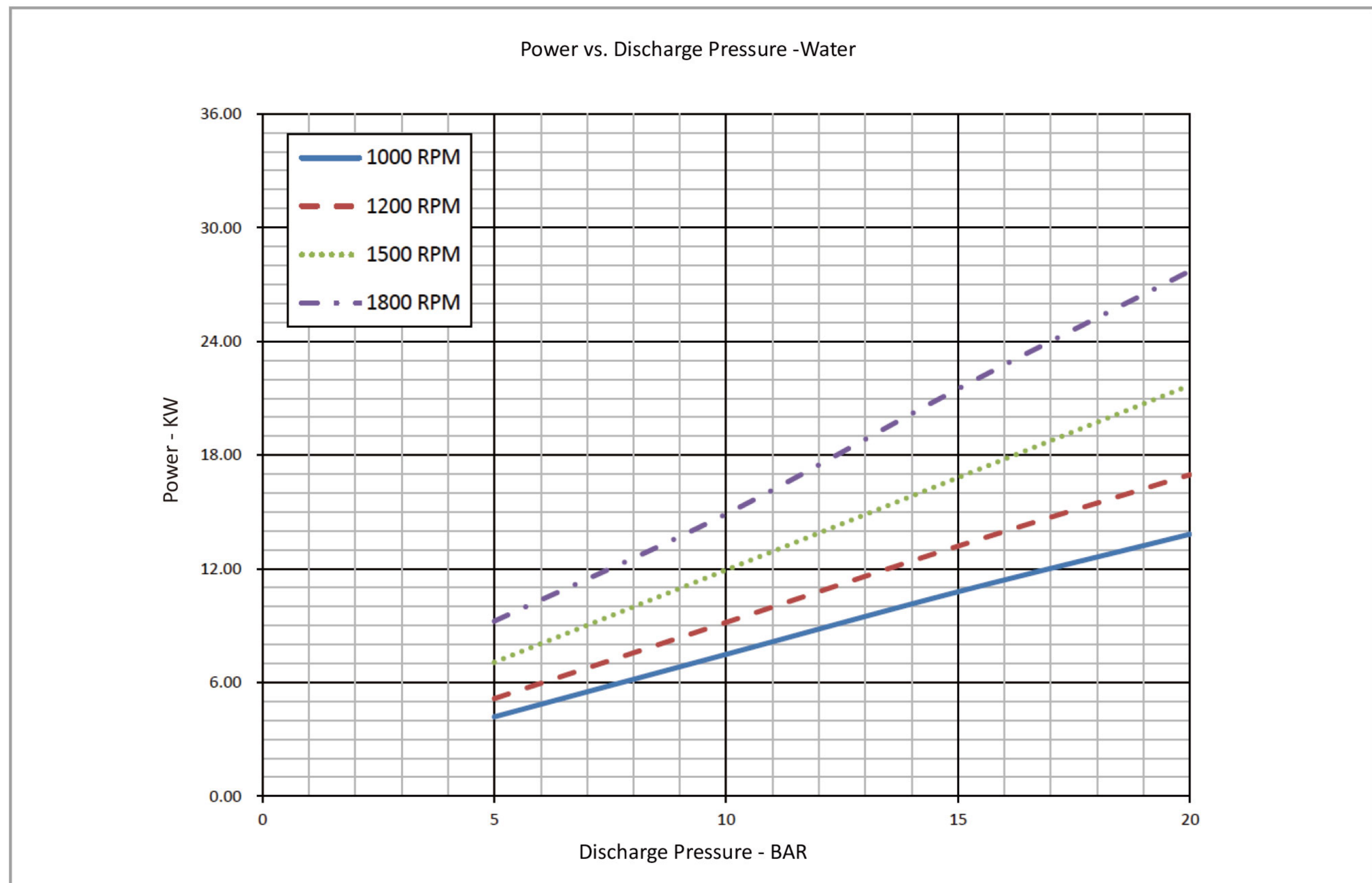
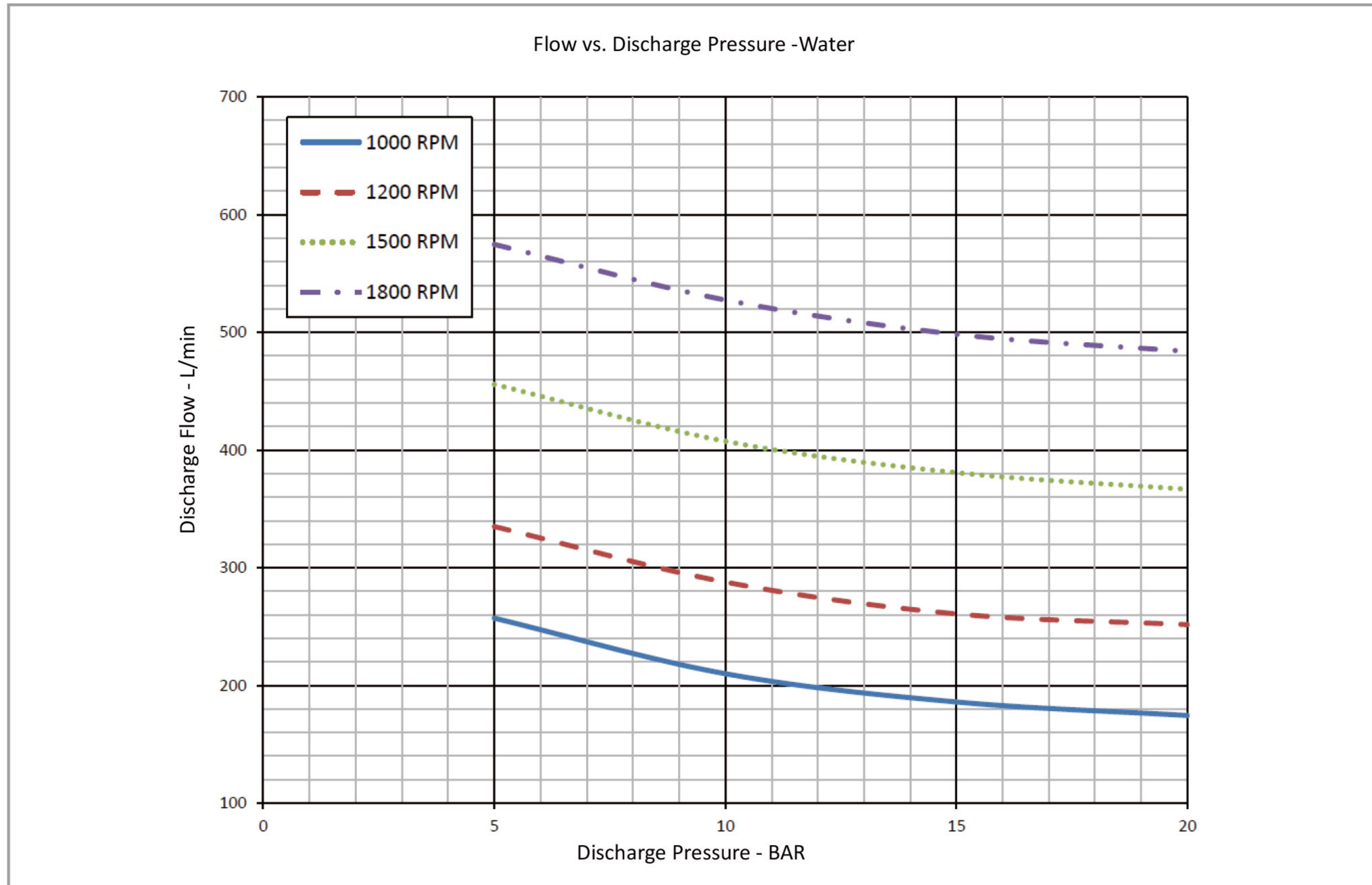

• The pump performance for foam concentrate, please contact Surex, or down load from www.surexfoam.com.