

Model G7-93 Rotary Gear Pump

Surex rotary gear pumps designed for foam extinguishing system. They are Self-Priming and can pump Multiple Viscosities of Foam or Water. This versatile design is suitable for Electric, PTO, Diesel/Gasoline Engine, Water Driven or Hydraulic drive motors.

Design Features:

- Timing Gears Synchronize the Two Pumping Rotors.
- Timing Gears Allow for DRY Running Without Damage.
- No Rotor Contact Allows for Pumping Foam or Water.
- Water Can Be Used for: Calibration, Testing and Training.

Technical Data:

Max Pressure: 2.0MPa | 20bar

Max Speed: 1800RPM

Viscosity : 9500cp max.[1]

Connection Diameter: DN50(60.3 O.D.)、2"

Connection Type: Groove、Thread、Flange

Approvals: FM

[1]Brookfield viscometer, spindle #4, speed 30rpm.

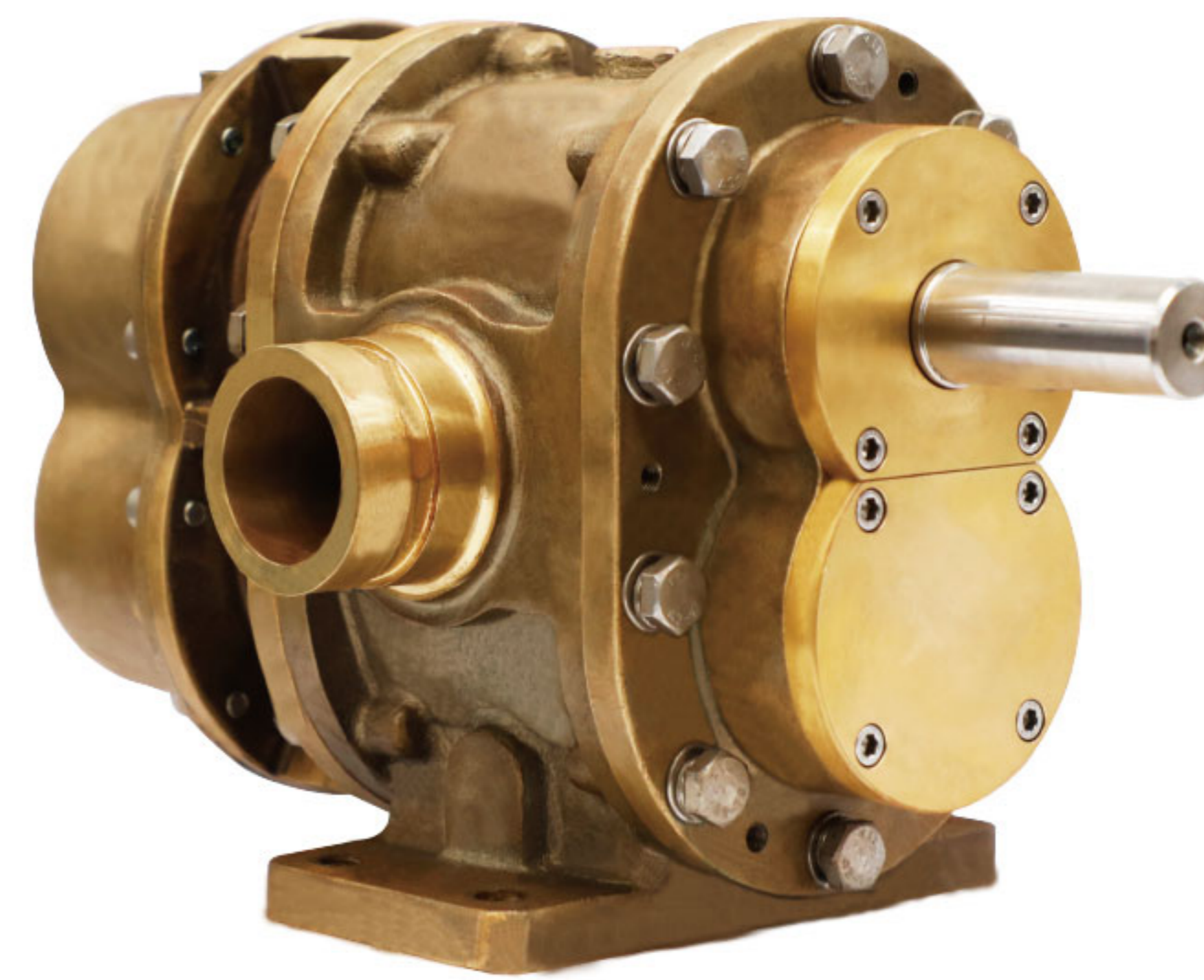

Materials :

Pump body: Red Brass, ASTM B584 C83600

Rotor: Stainless Steel 17-4PH
Red Brass, ASTM B584 C83600

Liners: Red Brass, ASTM B584 C83600

Front Cover: Red Brass, ASTM B584 C83600

Back Cover: Red Brass ASTM B584 C83600

Timing Gear: Alloy Steel 20CrMnTi (ASTM A29M)

Lip Seal : FPM

Performance -Water

Foam Pump	1000rpm			1200rpm			1500rpm			1800rpm			
	Pressure PSI	Flow GPM	Power HP	Torque LB-FT	Flow GPM	Power HP	Torque LB-FT	Flow GPM	Power HP	Torque LB-FT	Flow GPM	Power HP	Torque LB-FT
	72.5	51	5	25	67	6	25	92	8	29	115	10	30
	100	47	6	32	63	7	32	87	10	35	111	13	37
	150	41	8	45	57	10	45	81	13	47	105	17	49
	200	36	11	57	53	13	58	77	17	59	101	21	61
	250	33	13	69	50	16	70	74	20	71	98	25	73
	290	32	15	78	49	18	80	73	23	81	96	28	82

Dimensions

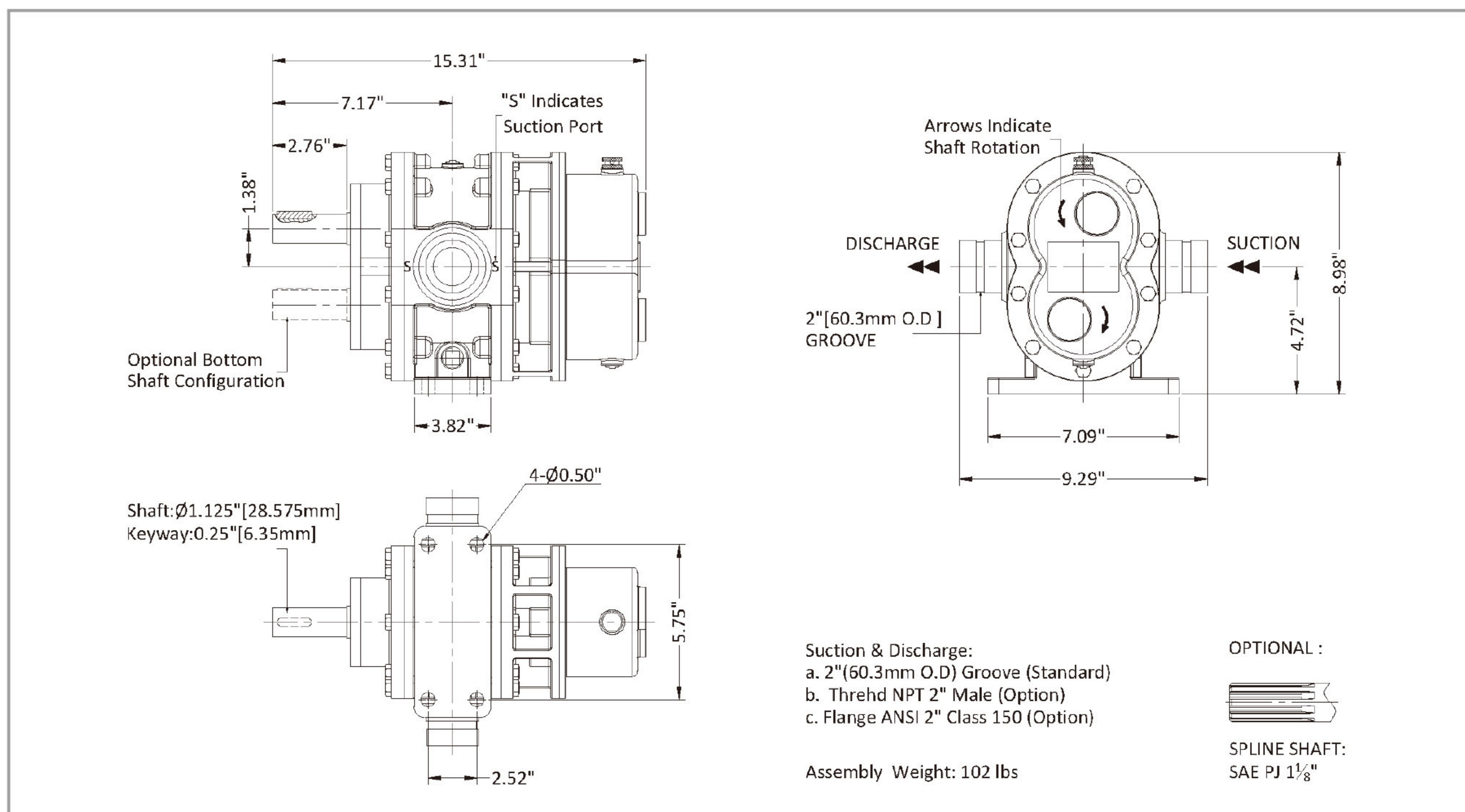

Model G7-93 Rotary Gear Pump

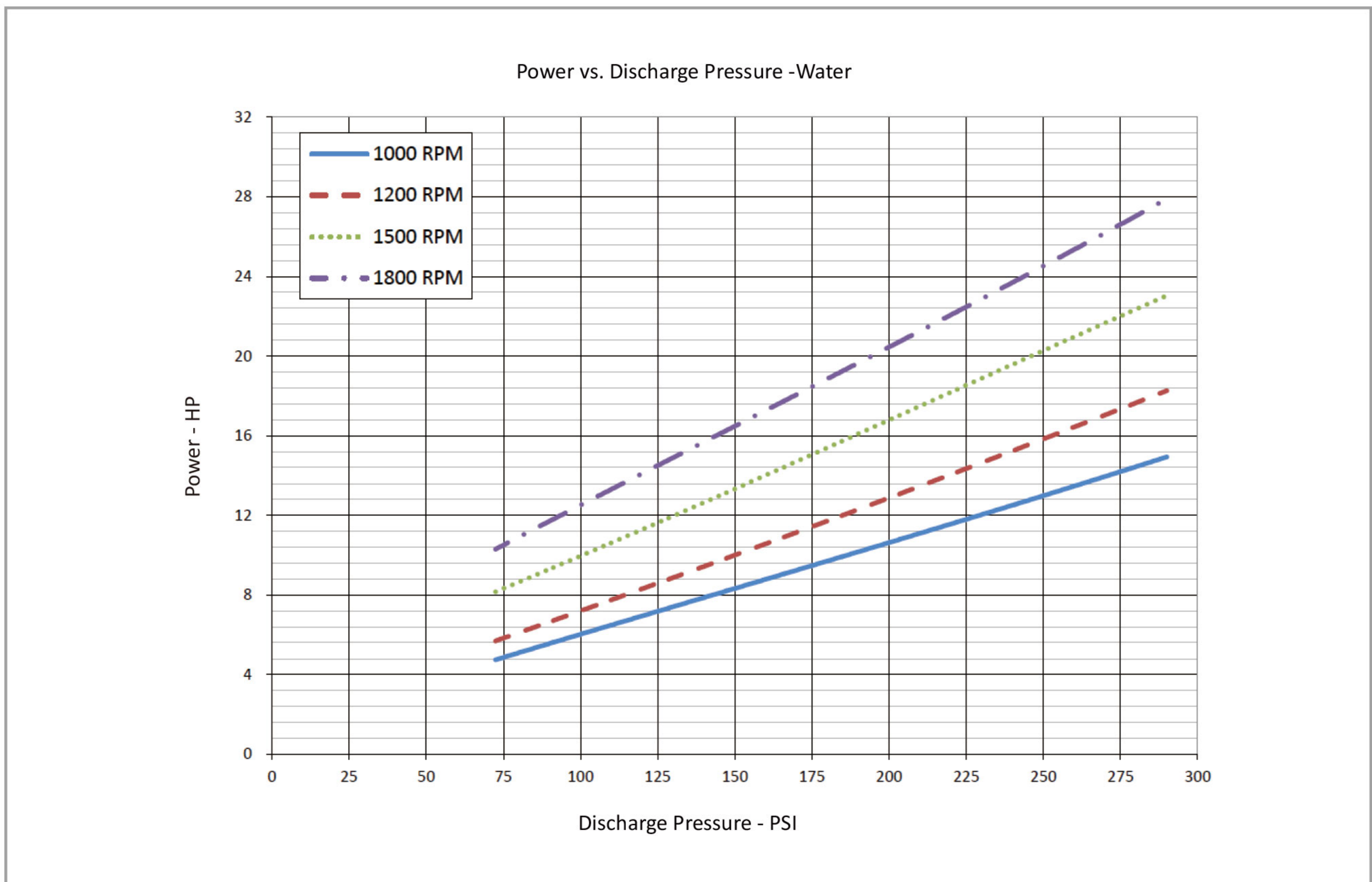
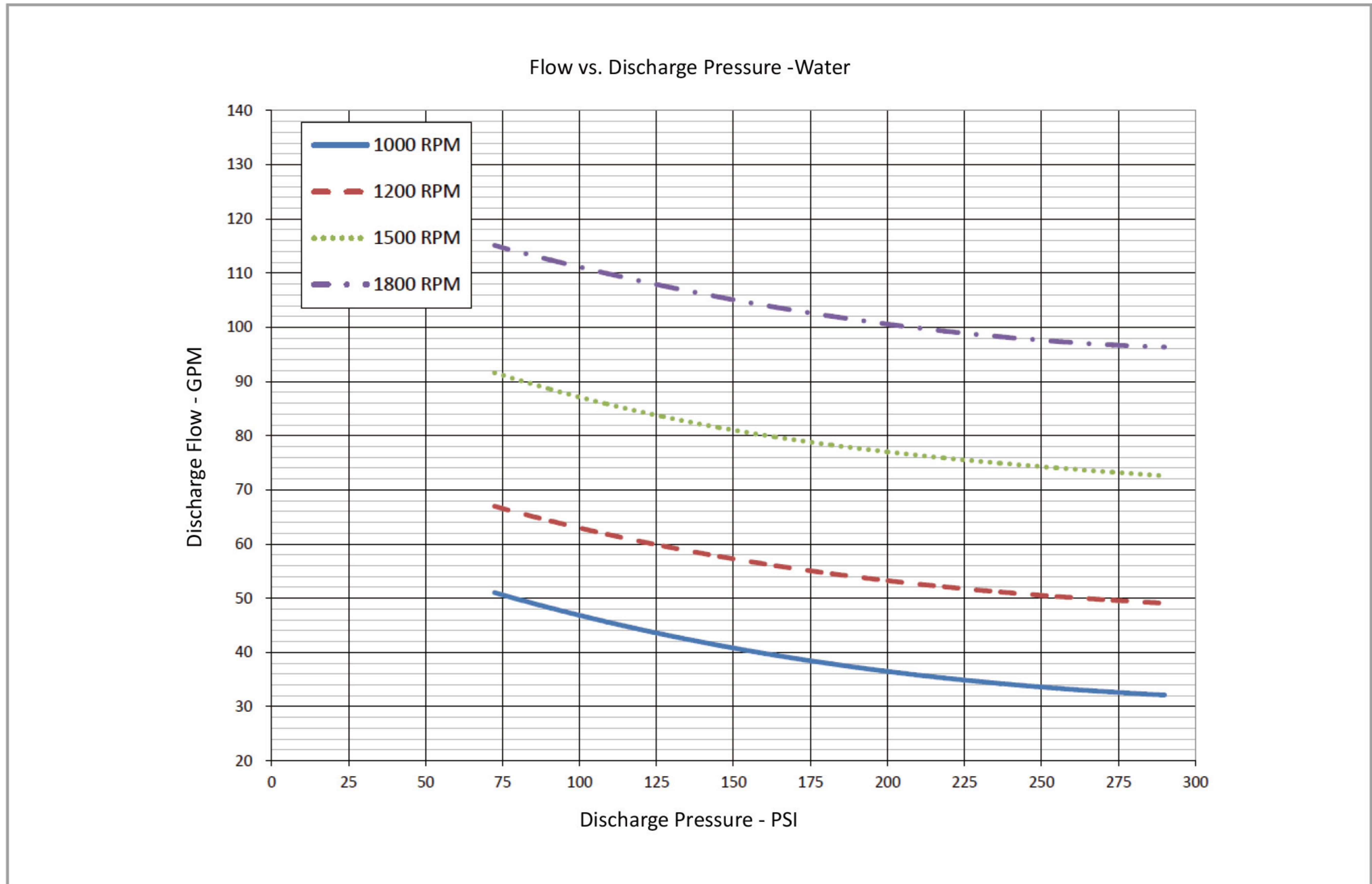

• The pump performance for foam concentrate, please contact Surex, or down load from www.surexfoam.com.